

Retail Operator General Manager	Sales New Motorcycles	Sales Pre-Owned Motorcycles	Business Manager (F&I)	Service	Parts & Accessories	Administration
Date: April 2013	Source: SI 12/2013		Name: Shawn McLean			
Bulletin # 31 001 13 (013)	Title: Service & Technical Manager		Phone: 201-307-4131			



BMW Motorrad USA Service Information Bulletin

****Notice of Recall 13V-154****

Subject: Front Fork Check

Model: R 1200 GS (K50)

Details: BMW Motorrad has ascertained that in rare cases the threaded sealing plug of the Telelever fixed fork tube can work loose. When a vehicle covers a high mileage a slack plug can come completely detached, with the result that steering movements can no longer be transmitted to the front forks to guide the front wheel.

A small number of motorcycles (16) are in the US market that have to be checked to ensure that the fork legs and plugs are in good order and the plugs then have to be crimp-locked to ensure that they cannot work loose.

Vehicles affected: In order to determine if a specific vehicle is affected by this Recall Campaign, it will be necessary to verify all vehicle VINs through a DCS Vehicle History Check. Based on the response of the system, either proceed with the repair or take no further action. Please note, affected VINs may not appear until 24-72 hours after the release of this bulletin.

NHTSA Statement: PERFORM THE PROCEDURE OUTLINED IN THIS SERVICE INFORMATION BULLETIN ON ALL AFFECTED VEHICLES BEFORE CUSTOMER DELIVERY OR THE NEXT TIME THE VEHICLE IS IN THE SHOP FOR MAINTENANCE OR REPAIRS.

BMW Motorcycle dealers must ensure recalls are completed after having been notified by BMW of North America, LLC (BMW Motorrad USA) that a safety-related defect or noncompliance exists in any motor vehicle or item of replacement equipment in the dealer's possession at the time of notification. In BMW NA's case, this notification would typically be made by the issuance of a recall notification in the form of a Service Information Bulletin (SIB) or transmission of a Dealer Communication System (DCS) recall message.

Under the National Traffic and Motor Vehicle Safety Act of 1966, as amended, if a recall campaign is announced by BMW NA, dealers must ensure that all recalls on vehicles and new items of replacement equipment are completed BEFORE delivery to the consumer. This means that dealers may not legally deliver new vehicles or new items of replacement equipment to consumers with an open recall.

The Safety Act also prohibits dealers from selling or leasing the vehicle or item of replacement equipment, unless and until the open recall has been completed BEFORE delivery. This also pertains to motorcycles in the Certified Pre-Owned program, and to items of replacement equipment.

Finally, BMW motorcycle dealers should not sell or use parts that have been recalled by BMW Motorrad USA. Please follow the specific instructions provided by BMW Motorrad USA on the return or disposition of the parts.

Aftersales Solution: All motorcycles affected by this problem must have both fixed fork tubes checked (see the description in the attached repair work item 00 60 267) and the threaded sealing plugs crimp-locked (see the description in attached repair work item 00 60 660).

In rare cases, the outcome of the check of the fixed fork tubes will be that either one or both fixed fork tubes will have to be replaced. Only in these cases is the additional warranty scope of relevance. See the description of the repair work item 31 42 849 (removing / installing fork legs) on the current RSD (Repair and Service Data BMW Motorrad) DVD. The procedure for repair work items 31 42 841 (left fork leg) and 31 42 842 (right fork leg) is analogous to that for repair work item 31 42 849 (both fork legs).

Warranty: The repair described in this bulletin is covered under warranty regardless of time or mileage. Reimbursement for this Recall Campaign is through normal claim entry utilizing the following information:

Warranty Processing Information:	Defect Code:	00 00 31 29 00	Crimp-locking fixed fork tubes
	Labor Codes:	00 60 267*	Checking security of fixed fork tube sealing plugs, 5 FRU
		00 60 660	Crimp-locking fixed fork tubes, 3 FRU

Additional warranty scope for replacing fixed fork tube(s):

Labor Codes:	31 42 849	Removing/installing fork legs, 7 FRU
	31 42 841	Removing/installing left fork leg, 5 FRU
	31 42 842	Removing/installing right fork leg, 5 FRU
	31 42 506	Replace fixed tube (fork leg removed), 2 FRU
Part Numbers:	31 42 8 549 470	Fixed fork tube (crimp-locked)
	31 42 7 684 743	Nut (1 per fork leg)
	31 42 8 532 723	Set of sealing elements (for 2 fixed fork tubes)

*Main Work 00 60 267 - this main labor operation crediting 5 FRU includes all repair procedures to complete the task with allowance for necessary ancillary tasks (e.g., visual inspection, lubrication, cleaning parts etc.) and administrative tasks.

Only one main labor operation can be claimed per repair visit. All other labor operations for any other line(s) must be claimed using plus code labor operations.

Please refer to the Warranty Policy and Procedures Manual regarding add-ons, proper support, documentation, claims submission and archiving requirements as applicable.

Important Note Regarding Special Tool Set 31 3 750: Special Tool Set 31 3 750 consists of the following three tools:

31 3 751	Crimp Locking Tool
31 3 752	Fork Clamp
31 3 753	Ring Spanner

Please contact the Service and Technical Manager at shawn.mclean@bmwna.com or 201-307-4131 to request a tool set (31 3 750) loan from BMW Motorrad USA. All tool set requests must note the affected VIN being repaired. Any tool sets not returned to BMW Motorrad USA in a timely manner will be the financial responsibility of the requesting dealer.

Contact: Service and Technical Manager

Work Item: 00 60 267 Checking security of fixed fork tube sealing plugs

Checking fixed fork tube sealing plug with feeler gauge

Push protective cap (1) down.

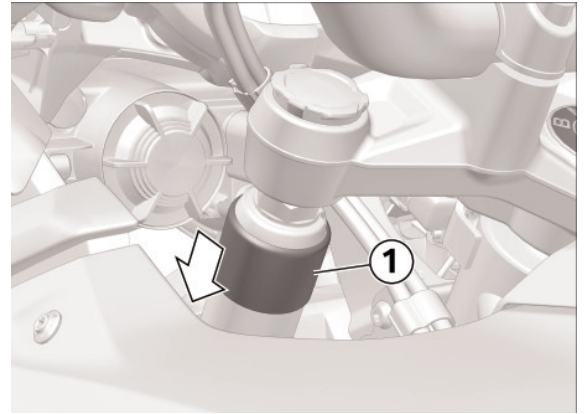

Check

Use feeler gauge (1) to check whether there is a gap between fixed fork tube sealing plug (2) and fixed fork tube (3).

Feeler Gauge Thickness: 0.05 mm

Result

There is a gap of at least 0.05 mm.

Measure

Replace the fixed fork tube (it is faulty).

Removing/installing fork legs (description in item No: 31 42 849, billing as separate line item).

Replacing fixed fork tube (fork leg removed) (description in work item: 31 42 506, bill as a separate item).

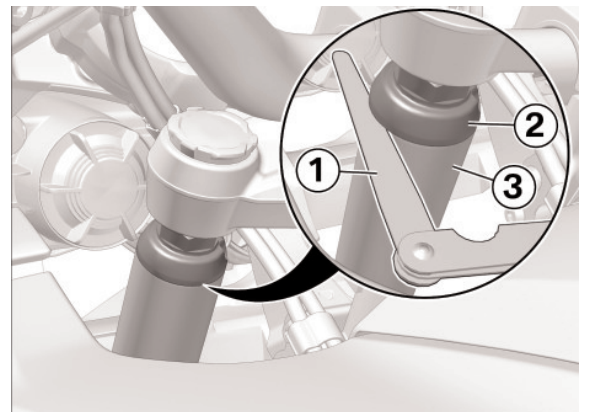

Result

There is no gap of at least 0.05 mm.

Measure

Check the security of fixed fork tube sealing plug.

Checking security of fixed fork tube sealing plug

Apply a mark (arrow) to fixed fork tube sealing plug (1) and fixed fork tube (2).

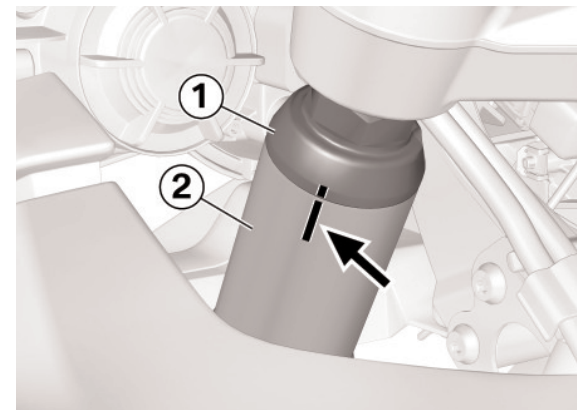

Hold fork clamp (31 3 752) in position at fixed fork tube (1) and tighten knob (2).

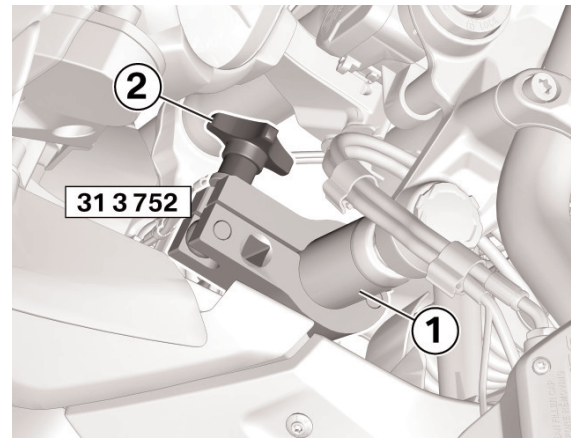

Counter-hold fixed fork tube sealing plug (1) with ring spanner (31 3 753) and 1/2" extension (2).

Check

Tighten fork clamp (31 3 752) counter-clockwise with torque wrench (3).

Note: The turning direction at the fixed fork tube has to be counter-clockwise for tightening the fixed fork tube sealing plug.

Test Torque: 50 Nm

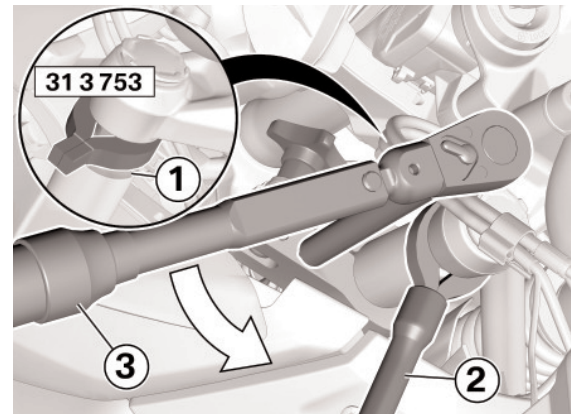

Result

Additional angle of rotation visible as indicated by the mark.

Measure

Replace the fixed fork tube (it is faulty).

Removing/installing fork legs (description in work item: 31 42 849, bill as a separate item).

Replacing fixed fork tube (fork leg removed) (description in work item: 31 42 506, bill as a separate item).

Result

No additional angle of rotation visible as indicated by the mark.

Measure

Crimp-locking fixed fork tubes (description in work item: 00 60 660, bill as a separate item).

Remove fork clamp (31 3 752) and ring spanner (31 3 753).

Work Item: 00 60 660 Crimp-locking fixed fork tubes

Crimp-locking fixed fork tube

Hold crimp-locking tool (31 3 751) in position at fixed fork tube (1) and seat it against fixed fork tube sealing plug (2).

Tighten screw (3).

Tightening torque for fixed fork tube crimp-locking tool: 40 Nm

Fixed fork tube is crimp-locked.

Slacken screw (3).

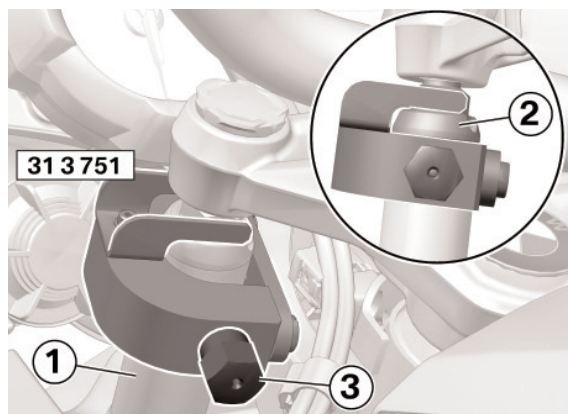

Turn fixed fork tube (1) through 90°.

Tighten screw (2).

Tightening torque for fixed fork tube crimp-locking tool: 40 Nm

Fixed fork tube is crimp-locked.

Slacken screw (2) and remove crimp-locking tool (31 3 751).

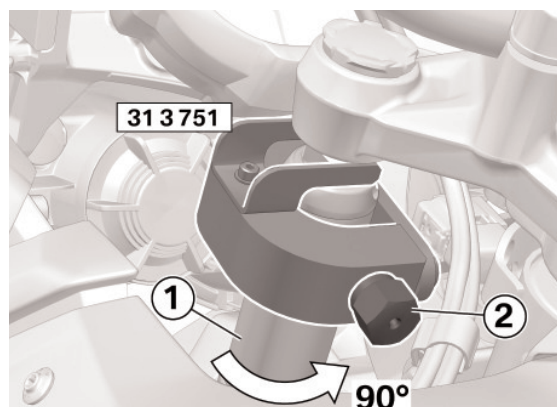

The crimp-locking points (arrows) must be at an angle of 90°.

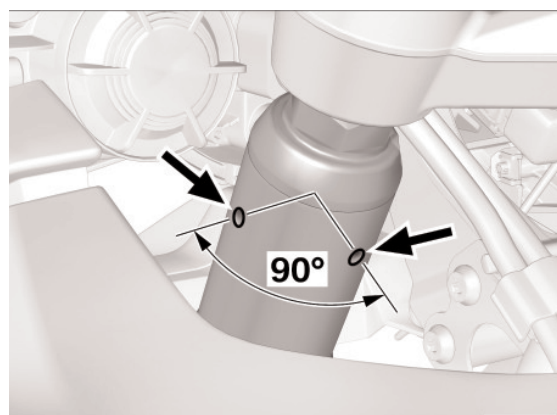

Push protective cap (1) up.

